

## Split System Indoor Coils

# Installation Instructions

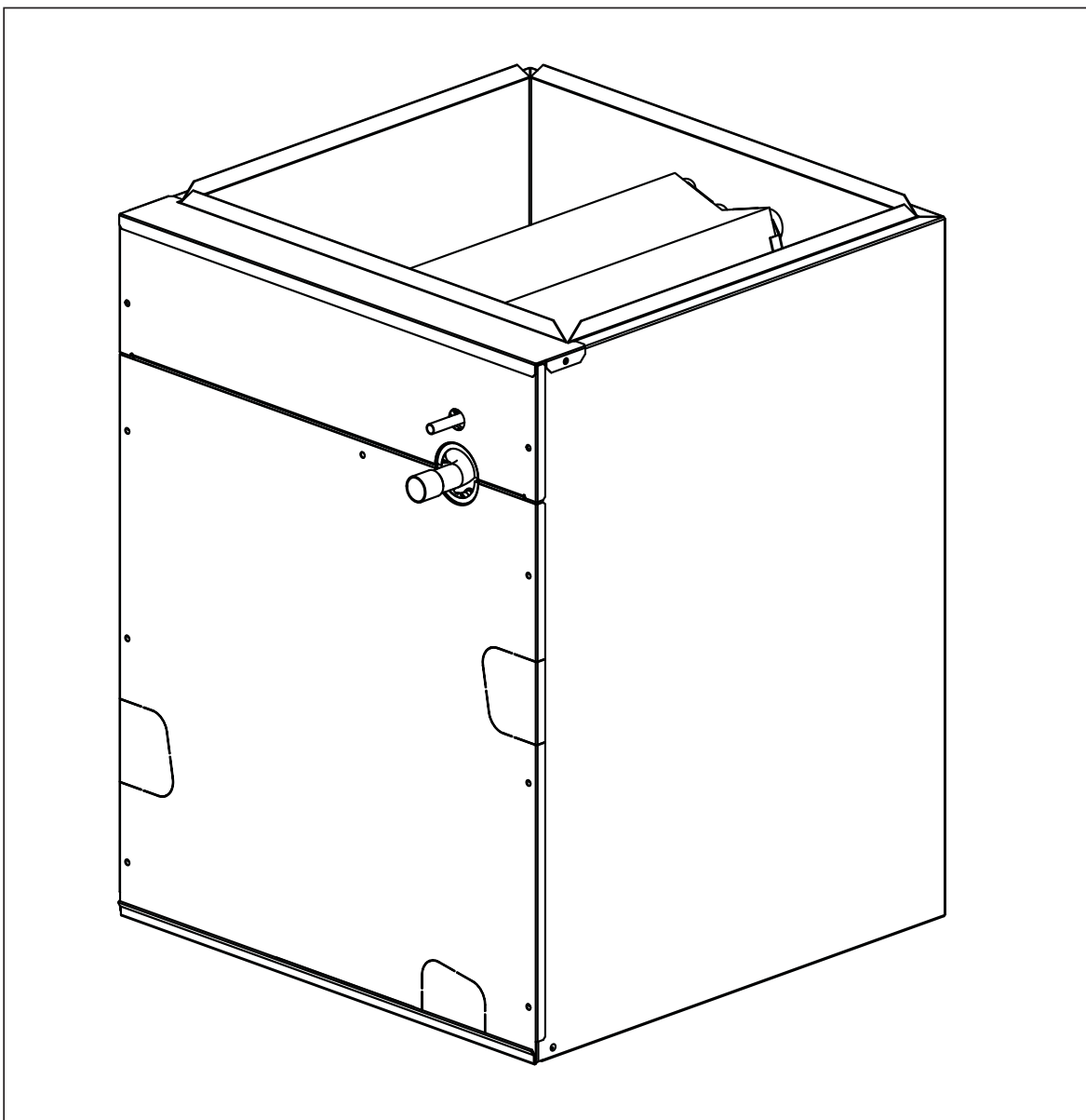

---

### **CAUTION:**

---

**Read the Installation Instructions supplied with furnace/air handler and observe all safety requirements outlined in instructions and/or furnace/air handler markings before proceeding with installation of the coil**

---

These instructions are primarily intended to assist qualified individuals experienced in the proper installation of this appliance. Some local and national codes require licensed installation/service personnel for this type of equipment. Read all instructions carefully before starting the installation.

---

## Table of Contents

<b>1. General Information .....</b>	<b>3</b>
<b>2. Coil Specifications .....</b>	<b>4</b>
<b>3. Coil Installation.....</b>	<b>5</b>
• Upflow Furnace	
• Downflow Furnace	
• Horizontal Furnace	
• Horizontal Ready Coils for Horizontal Left Installation	
• Horizontal Ready Coils for Horizontal Right Installation	
<b>4. Verify Pressurization .....</b>	<b>6</b>
<b>5. Refrigerant Line Connections .....</b>	<b>6</b>
<b>6. Completing the Installation .....</b>	<b>7</b>
• Condensate Drain	
• Air Filters	
• Close-off Plates and Panels	
• Refrigerant Charging	
<b>7. Maintenance and Service .....</b>	<b>7</b>

## 1. GENERAL INFORMATION

Standard cased coils are designed for upflow/downflow applications or horizontal applications when used in conjunction with our horizontal drain pan kit (See page 5). Accessory kits are not required for factory ready horizontal coils. Coils are equipped with braze type refrigerant connections for easy installation.

Read the installation manual supplied with the outdoor unit for refrigerant line connection procedure, required line sizes, and other information pertaining to the system installation.

1. Make certain that the air delivery of the furnace/air handler is adequate to handle the static pressure drop of the coil, filter, and duct work.
2. Check the orifice size of the coil's expansion device and confirm that it is suitable for application with the intended outdoor unit.  
**NOTE:** Some coils employ a thermostatic expansion valve (TXV) as the metering device (See page 4).

3. Where precise forming of the refrigerant lines is required, a copper tubing bender designed for the size lines used is recommended. Avoid sharp bends and contact of the refrigerant lines with metal surfaces.
4. Refrigerant lines should be wrapped with pressure sensitive neoprene or other suitable material where they pass through the raw edges of holes.
5. Coil must be level for proper condensate drainage.

**NOTE:** Optional cooling/heating equipment must be properly sized and installed in accordance with the furnace manufacturer's specifications and approved recommendations. "Heating only" furnace air circulators may have to be replaced with multi-speed "Heating/Cooling" blowers to upgrade the air delivery (CFM) when an add-on coil is installed. Refer to Coil Specifications for recommended CFM and allow for pressure drop across the coil and filters.

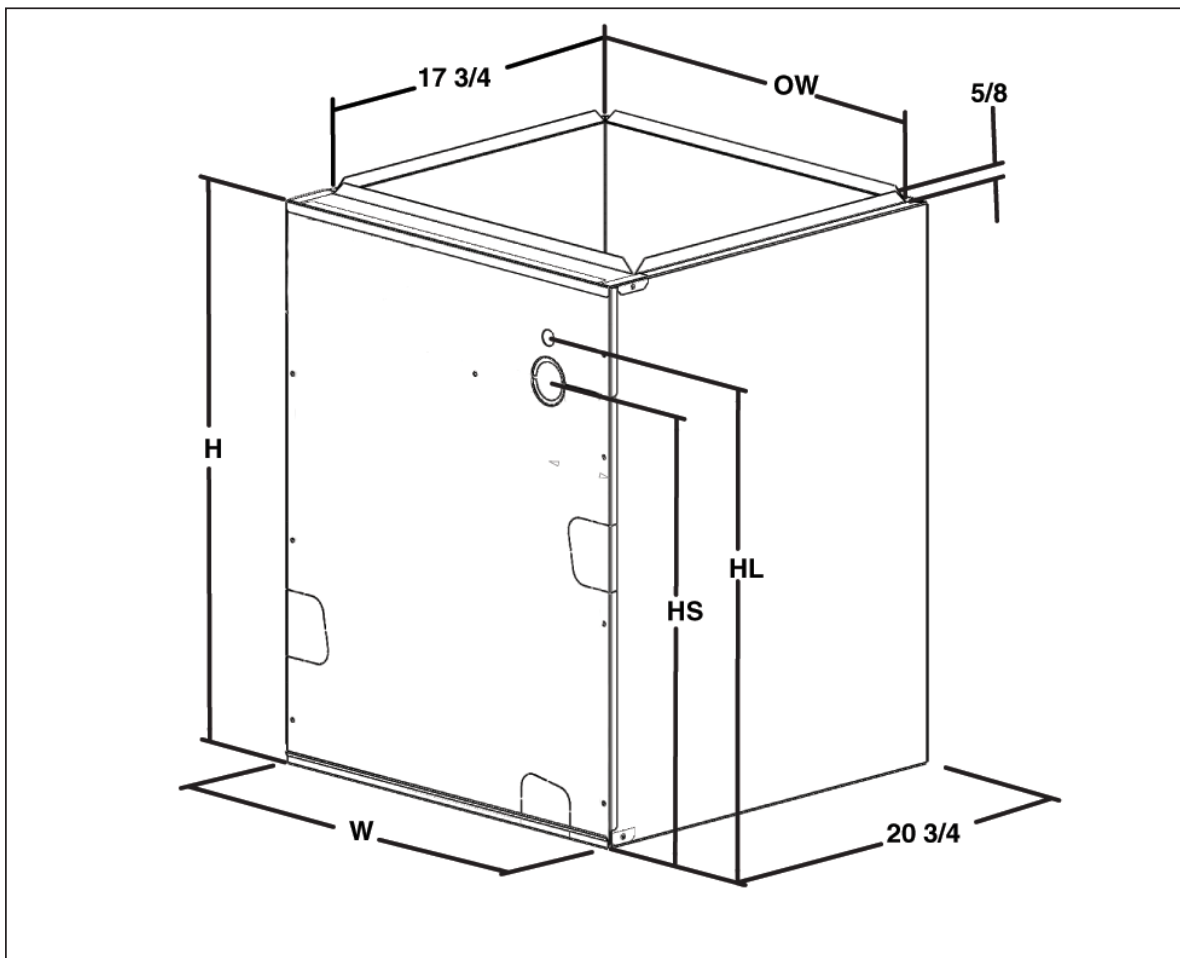

Figure 1.

## 2. COIL SPECIFICATIONS

TABLE 1 - C6 CASED COIL SPECIFICATIONS

Cased Coil Model Cased C6BA (1)(2)	T24-A	T30-A	T24-B	T30-B	T36-B	T42-B	T36-C	T42-C	T48-C	T60-C	T42-D	T48-D	T60-D
	X24-A	X30-A	X24-B	X30-B	X36-B	X24-B	X36-C	X42-C	X48-C	X60-C	X42-D	X48-D	X60-D
Nominal Capacity BTUH (3)	24,000	30,000	24,000	30,000	36,000	24,000	36,000	42,000	48,000	60,000	42,000	48,000	60,000
Metering Device	TXV	TXV	TXV	TXV	TXV	TXV	TXV	TXV	TXV	TXV	TXV	TXV	TXV
Nominal Airflow (CFM)	800	1,000	800	1,000	1,200	1,200	1,200	1,400	1,600	2,000	1,400	1,600	2,000
W - Width (in.)	14 1/2	14 1/2	17 1/2	17 1/2	17 1/2	17 1/2	17 1/2	21	21	21	24 1/2	24 1/2	24 1/2
H - Height (in.)	20 3/4	20 3/4	20 3/4	20 3/4	20 3/4	26 3/4	26 3/4	26 3/4	30 1/4	30 1/4	30 1/4	30 1/4	30 1/4
HL - Height of Liquid Line (in.)	17 1/2	17 1/2	17 1/2	17 1/2	17 1/2	23 1/2	23 1/2	23 1/2	27	27	27	27	27
HS - Height of Suction Line (in.)	15 1/2	15 1/2	15 1/2	15 1/2	15 1/2	21 1/2	21 1/2	21 1/2	25	25	25	25	25
Connection - Liquid Line	3/8	3/8	3/8	3/8	3/8	3/4	3/4	3/8	3/8	3/8	3/8	3/8	3/8
Connection - Suction Line	3/4	3/4	3/4	3/4	3/4	3/4	3/4	7/8	7/8	7/8	7/8	7/8	7/8
Horizontal Drain Kit (4)	920265	920265	920265	920266	920265	920266	920265	920266	920266	920267	920267	920267	920267

TABLE 2 - C6 HORIZONTAL CASED COIL SPECIFICATIONS

Cased Coil Model C6BH (1)(2)	T24-A	T30-A	T24-B	T30-B	T36-B	T42-B	T36-C	T42-C	T48-C	T60-C	T42-D	T48-D	T60-D
	X24-A	X30-A	X24-B	X30-B	X36-B	X24-B	X36-C	X42-C	X48-C	X60-C	X42-D	X48-D	X60-D
Nominal Capacity BTUH (3)	24,000	30,000	24,000	30,000	36,000	24,000	36,000	42,000	48,000	60,000	42,000	48,000	60,000
Metering Device	TXV	TXV	TXV	TXV	TXV	TXV	TXV	TXV	TXV	TXV	TXV	TXV	TXV
Nominal Airflow (CFM)	800	1,000	800	1,000	1,200	1,200	1,200	1,400	1,600	2,000	1,400	1,600	2,000
W - Width (in.)	14 1/4	14 1/4	17 1/2	17 1/2	17 1/2	17 1/2	17 1/2	21	21	21	24 1/2	24 1/2	24 1/2
H - Height (in.)	26 3/4	26 3/4	26 3/4	26 3/4	26 3/4	26 3/4	26 3/4	26 3/4	30 1/4	30 1/4	30 1/4	30 1/4	30 1/4
HL - Height of Liquid Line (in.)	23 1/2	23 1/2	23 1/2	23 1/2	23 1/2	23 1/2	23 1/2	23 1/2	27	27	27	27	27
HS - Height of Suction Line (in.)	21 1/2	21 1/2	21 1/2	21 1/2	21 1/2	21 1/2	21 1/2	21 1/2	25	25	25	25	25
Connection - Liquid Line	3/8	3/8	3/8	3/8	3/8	3/8	3/8	3/8	3/8	3/8	3/8	3/8	3/8
Connection - Suction Line	3/4	3/4	3/4	3/4	3/4	3/4	3/4	7/8	7/8	7/8	7/8	7/8	7/8
	920265	920265	920265	920266	920265	920266	920265	920266	920266	920267	920267	920267	920267

(1) Refer to sales specification sheets for Listed/Certified combinations of equipment and required accessories.

(2) X in the model description designates factory installed TXV for R-410a refrigerant.

T in the model description designates factory installed TXV for R-22 refrigerant.

(3) Refer to the current ARI Directory for certified ratings of split systems.

(4) Not required for "H" horizontal ready coils.

### 3. COIL INSTALLATION

---

## WARNING:

---

**Electric furnaces may be connected to more than one supply circuit.**

---

#### Upflow Furnace —

1. Disconnect all electrical power to the furnace.
2. If needed, use one of the coil case adapter kits to match the coil to the furnace air discharge opening. Refer to the Coil Specifications Section for proper kit numbers.
3. Install the coil and level it as needed to ensure proper condensate drainage. (See Figure 2)
4. Seal the enclosure as required to minimize air leakage.
5. Connect the refrigerant lines as outlined in the Refrigerant Lines section.

**Downflow** — These coils may be installed in downflow applications. Installation of the coils in these applications only require that the furnace and coil cabinets are securely mounted together before setting in place. Fossil fuel applications require coil to be placed in the supply air stream only.

**Horizontal** — Standard coils may also be installed in horizontal applications. Installation of the standard coils in these applications only require that the furnace and coil cabinets are securely mounted together and that a

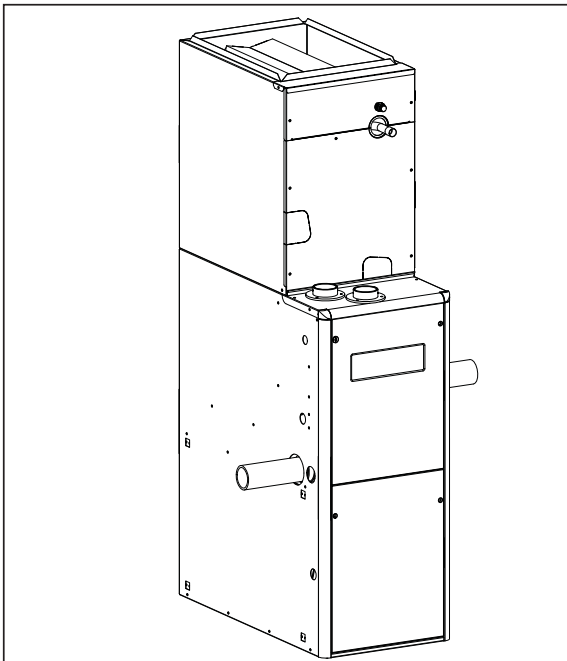

**Figure 2. Upflow Furnace Application**

horizontal drain pan kit be installed. Refer to the Specifications Section for proper kit numbers.

#### **To Configure Horizontal Ready Coils for Horizontal LEFT Installations:**

- 1) Remove the coil access door.
- 2) **IMPORTANT:** Remove the plug from one of the threaded holes in the horizontal drain pan. Completely remove the webbing located in the threaded holes of the horizontal drain pan. If webbing is not removed, the drain will not function properly and ceiling damage may occur.
- 3) Insert a plug (from the horizontal drain pan) into the open and unused drain hole in the drain pan at the bottom of the unit to block bypass air.
- 4) Remove the corresponding drain line knockout from the coil access door to allow access to the horizontal drain.
- 5) Replace the door.

**NOTE:** Install drainpan extension (supplied) on the following models:

C5BH-*60	C4BH-X36
C5BH-*49	C4BH-X48
	C4BH-X60

#### **To Configure Horizontal Ready Coils for Horizontal RIGHT Installations:**

- 1) Remove the coil access door. Unscrew the line-set tube close-off plate from the front left cabinet rail.
- 2) Slide the coil and drain pan assembly out of the unit.
- 3) **IMPORTANT:** Remove the plug from one of the threaded holes in the horizontal drain pan. Completely remove the webbing located in the threaded holes of the drain pan. If webbing is not removed, the drain will not function properly and ceiling damage may occur.
- 4) Remove the sheet metal hairpin covers (if supplied) from the back of the coil and discard.
- 5) Place the horizontal drain pan on the opposite side of the coil. On units with 2 sets of knockouts, remove the other set of knockouts in the coil spacing plates and insert support rod.
- 6) Insert a plug (from the horizontal drain pan) into the open and unused drain hole in the drain pan at the bottom of the unit to block bypass air.
- 7) Slide the coil and the horizontal drain pan assembly back into the unit. Reattach the tube close off plate.

- 8) Remove the corresponding drain line knockout from the coil access door to allow access to the horizontal drain.
- 9) Replace the door.

**NOTE:** Install drainpan extension (supplied) on the following models:

C5BH-*60	C4BH-X36
C5BH-*49	C4BH-X48
	C4BH-X60

**Note:** All condensate pans have primary and secondary drain connections to meet FHA requirements. If the application is located in or above a living space where damage may result from condensate overflow, a separate 3/4 inch drain must be provided from the secondary drain connection and a secondary drain pan must be installed under the entire unit. Run secondary drain lines to a place where they are noticeable if used.

#### 4. VERIFY PRESSURIZATION

---

### **WARNING:**

---

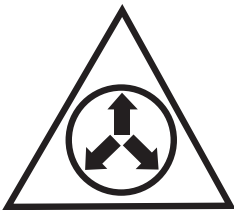

NITROGEN	
HEALTH	1
FLAMMABILITY	0
REACTIVITY	0
0 Minimal Hazard    1 Slight Hazard	

**This coil is pressurized with Nitrogen. Avoid direct face exposure or contact with valve when gas is escaping. Always ensure adequate ventilation is present during the depressurization process. Any uncertainties should be addressed before proceeding.**

---

#### VERIFY PRESSURIZATION:

- Test by depressing Schrader valve and listen for escaping gas
- If no pressure is found, test coil for leak
  - If no leak is found, install coil
  - If leak is found, clearly mark leak location and return coil to your distributor for processing

#### 5. REFRIGERANT LINE CONNECTIONS

---

### **WARNING:**

---

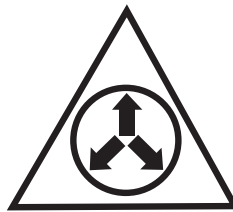

NITROGEN	
HEALTH	1
FLAMMABILITY	0
REACTIVITY	0
0 Minimal Hazard    1 Slight Hazard	

**This coil is pressurized with Nitrogen. Avoid direct face exposure or contact with valve when gas is escaping. Always ensure adequate ventilation is present during the depressurization process. Any uncertainties should be addressed before proceeding.**

---

#### Line Connections:

1. Making note of orientation, remove the hole grommet from around the refrigerant line set connection.
2. Remove the valve cap from the end of the liquid line. Relieve all pressure from the coil by depressing the valve.
3. Remove the valve core and valve core holder on the liquid line. **DO NOT** reuse the valve, threaded valve holder or O-Ring.
4. It is recommended to wrap a wet rag around the suction line between the sensing bulb and the line set braze joint before applying any heat.
5. Unbraze and remove the cap on the suction line.
6. Properly dispose of all removed parts.
7. Cut the line set tubing to the proper length. Be sure that the tubing has been sized in accordance with the outdoor unit specifications.
8. Inspect both refrigerant lines. The ends of the lines must be round, clean, and free of any burrs.
9. Place grommets in proper orientation onto line set with sufficient distance to braze joint.
10. Insert the suction line set tube into the coil suction tube stub until it bottoms out.
11. Slip the nut from the schrader valve holder onto the liquid line - check for correct orientation. Insert liquid line into liquid line stub until it bottoms out. Liquid line stub is shipped with the coil but is not attached.

12. Braze the individual connections with dry nitrogen flowing through the joints to eliminate internal oxidation and scaling.
13. Fasten nut to secure the liquid line to the bulkhead fitting. No O-Ring is required.
14. Check the assembly for leaks.
15. On horizontal applications of models with TXV valve, re-position the sensing bulb on the suction line so it is in the 4 o'clock or 8 o'clock position on the suction tube.
16. Properly dispose of all removed parts.

## 6. COMPLETING THE INSTALLATION

---

### CAUTION:

**The indoor coil must be checked to ensure a level installation. Failure to do so may result in improper condensate disposal, causing structural damage, premature equipment failure, or possible personal injury.**

---

#### Condensate Drain —

1. The coil condensate pan is furnished with 3/4" NPSC drain connections. Use a PVC or similar material fitting to attach the drain line to the pan. The fitting should be hand tightened only. **Overtightening may crack the drain pan and cause a condensate leak.**
2. Connect the drain line and run to a suitable drain avoiding sharp bends and pinching of the line. Install a condensate trap and prime with water.
3. During the system checkout, inspect the drain line and connections to verify proper condensate disposal.
4. Perform any necessary adjustments to the coil components to ensure that all drip points fall within the outline of the drain pan.

**Air Filter** — Air filters are not provided as an integral part of this coil, however, a filter must be installed upstream of the coil and inspected frequently. When the filter becomes clogged with dust or lint, it should be replaced (disposable type) or cleaned (washable type). The filter should be inspected and replaced or cleaned at least twice during the year, generally at the start of each heating and cooling season.

**Close-Off Plates and Panels** — Install the necessary air close-off plates around the refrigerant lines and drain line where required. Reinstall all inner and outer panels of the coil

case and furnace that were previously removed to install the indoor coil.

**Refrigerant Charging** — These cased indoor coils are not factory charged with refrigerant.

It will be necessary to evacuate the indoor coil and line set prior to charging. Refer to the outdoor unit installation manual for detailed charges and instructions.

## 7. MAINTENANCE AND SERVICE

---

### WARNING:

**Ensure that all electrical power to the furnace and outdoor (condensing) unit is off before performing any maintenance or service on the system.**

---

To ensure optimum performance and to minimize possible equipment failure, the following periodic maintenance should be performed on this equipment:

1. The air filter installed with the system should be checked and cleaned or replaced twice per year.
2. Check the coil, drain pan, and condensate drain line for cleanliness at the start of each heating and cooling season. Clean as needed.

---

### CAUTION:

**Do not operate the system without having a suitable filter in place in the return air duct system. Always replace the filter with the same size and type.**

---

**INSTALLER: PLEASE LEAVE THESE  
INSTALLATION INSTRUCTIONS WITH  
THE HOMEOWNER**



**708823D**



**708823D** (Replaces 708823C)

O'Fallon, MO

**NORDYNE**

Specifications and illustrations subject to change  
without notice and without incurring obligations.  
Printed in U.S.A. (07/08)